

OILPATH

OP101

DOUBLE LOCK VALVE



OP 101/I

For insertion in hose lines between control valve and double acting cylinder



OP 101/C

For direct mounting to double acting cylinder base port and via metal tubeline to gland port

Features:

- Manufactured from aluminium alloy
- Hardened steel check seats
- Pilot spool area to check seat area ratio 3:1
- Flow capacity up to 12 gpm (54 litres)
- Working pressure up to 3000 psi (20.68 MPa)
- Standard port size 1/2" BSP-T

Schematic

Cutaway view and parts diagram shown for model OP101/C.
For model OP101/I replace 3/4" JIC nipple (11) with 1 1/8" plug (1) and remove port plug (10).

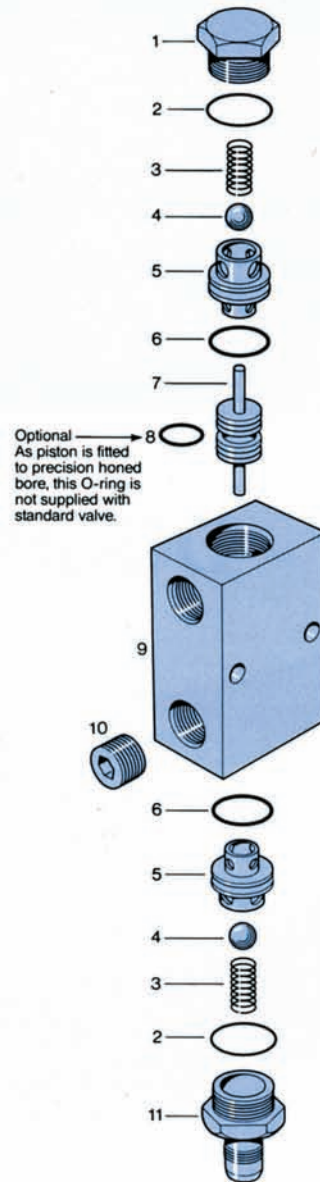
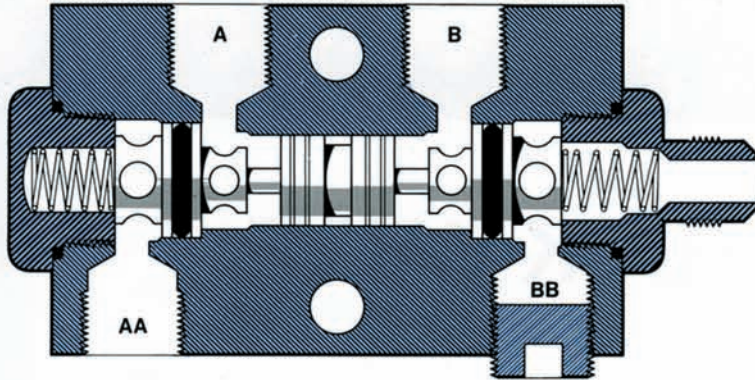
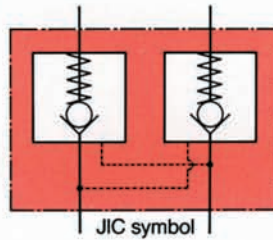

Optional
As piston is fitted to precision honed bore, this O-ring is not supplied with standard valve.

Dimensions

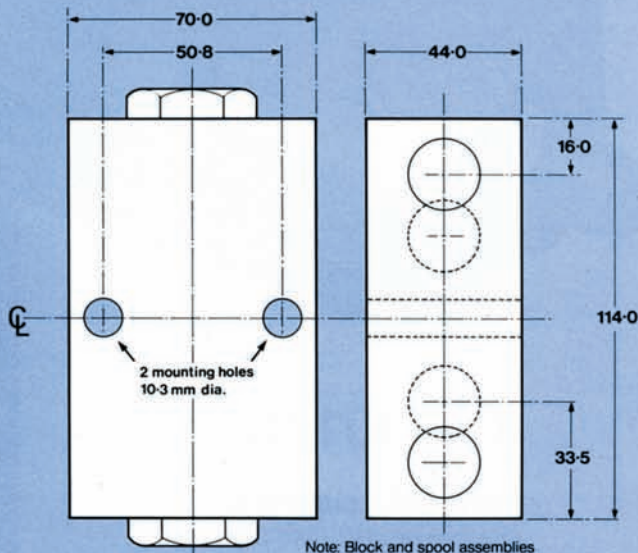

Options (available on special order)

- 3/4" UNF O-ring 16 TPI ports
- 3/8" BSP-T ports
- Piston fitted with O-ring

Warranty

Oilpath products are warranted to be free of defects in material or workmanship.

This Warranty voids all other warranties, whether expressed or implied, and shall be in effect for six months. The Warranty is limited to replacement or repair, excluding seals or damage arising from misuse or incorrect fitting.

The Company accepts no liability for faults caused by improper use or faulty maintenance of the product, or its operation beyond recommended specifications or contingent or consequential loss or damage under any situation whatsoever.

All unauthorised modifications to the product automatically voids the conditions of this Warranty.

Ref.	Part	Item	Ref.	Part	Item
1	101-1	1 1/8" UNF plug	7	101-7	Piston
2	101-2	O-ring, BS119	8	101-8	O-ring, BS113
3	101-3	Spring	9	101-9	Body
4	101-4	Ball, 1/2"	10	101-10	Plug, 1/2" BSP-T
5	101-5	Seat cage	11	101-11	Nipple, 3/4" JIC
6	101-6	O-ring, BS116			

Manufactured by :

OILPATH PTY. LTD.
INC. IN SOUTH AUSTRALIA
A.B.N. 97 007 683 472

21 Deloraine Road,
Edwardstown, South Australia.
PO Box 132, Edwardstown 5039,
Ph: (08) 8277 4933 Fax: (08) 8277 9126

JB0785