

**RYCO**

**AIR**

**Super-Hi-Flow  
Airline  
Couplings**

**Blow Guns  
Air Chucks  
Coupling Nipples  
Automatic Couplings**



## RYCO AIRLINE COUPLINGS – FEATURES

### RUGGED – LONG LASTING

All **RYCO AIRLINE** Couplings have stainless steel springs and balls, synthetic rubber seals, and brass or hardened steel sleeves. Australian designed, for Australian conditions.

### SUPER-HI-FLOW

Efficient “Super-Hi-Flow” design produces maximum airflow, with minimum pressure drop. This means more air-power at your tool...where you need it.

### ONE TOUCH OPERATION

Retract the sleeve on 290 and 500 Series – “one touch” – and the nipple ejects from the coupling. The sleeve remains in the release position. To reconnect, 290, 500 and 500R Series simply push together with their nipples – “one touch” – to seal and lock – no need to retract the sleeve again. The sleeve snaps forward to confirm positive connection.

### SELF SEALING – 360° SWIVEL

Couplings can be coupled and uncoupled up to 17,2 bar/250 psi line pressure. The valve in the coupling automatically seals when your tool is disconnected. Nipple is unvalved. 360° swivel feature allows free movement when unpressurised to avoid hose kinking or twisting.

### THREAD LOCKED

Our Automatic Couplings are thread-locked on assembly to eradicate damage from high frequency vibration. **300** Series feature Crimp Ring construction.

## THE RYCO AIRPOWER RANGE – SPECIFICATIONS

**Recommended for:** General industrial pneumatic use with air compressors, air hoses, blow guns, air driven hand tools, air supply to spray painting equipment, tyre inflating equipment, etc.

Only **RYCO 500R** Series Couplings are recommended for Respiratory Breathing Air.

**RYCO 500R** and all other **RYCO** Series are **NOT RECOMMENDED** for Underwater Diving applications.

## SPECIFICATIONS

SERIES	200 SERIES BRASS	200S SERIES STEEL	290 SERIES SUPER-HI-FLOW	300 SERIES INDUSTRIAL	400 SERIES SUPER-HI-FLOW	500 SERIES SUPER-HI-FLOW	500R SERIES BREATHING AIR
<b>FLOW CAPACITY</b> CFM @ 7 bar/100 psi LPM	45 1300	45 1300	90 2500	165 4700	90 2500	100 2800	100 2800
<b>MAX. WORKING PRESSURE</b> bar psi	15 220	20 290	35 500	35 500	15 220	35 500	35 500
<b>TEMPERATURE RANGE</b>	-20°C to +80°C -4°F to +176°F	-20°C to +80°C -4°F to +176°F	-20°C to +80°C -4°F to +176°F	-20°C to +80°C -4°F to +176°F	-20°C to +80°C -4°F to +176°F	-20°C to +80°C -4°F to +176°F	-20°C to +80°C -4°F to +176°F

## MATERIAL

<b>BODY</b>	BRASS	STEEL	STEEL	STEEL	STEEL	STEEL	BRASS
<b>SLEEVE</b>	BRASS	HARDENED STEEL	HARDENED STEEL	HARDENED STEEL	HARDENED STEEL	HARDENED STEEL	BRASS
<b>SEALS</b>	NITRILE	NITRILE	NITRILE	NITRILE	NITRILE	NITRILE	NITRILE
<b>BALLS</b>	STAINLESS STEEL	STAINLESS STEEL	STAINLESS STEEL	STAINLESS STEEL	STAINLESS STEEL	STAINLESS STEEL	STAINLESS STEEL
<b>SPRING</b>	STAINLESS STEEL	STAINLESS STEEL	STAINLESS STEEL	STAINLESS STEEL	STAINLESS STEEL	STAINLESS STEEL	STAINLESS STEEL
<b>NIPPLE</b>	BRASS	HARDENED STEEL	HARDENED STEEL	HARDENED STEEL	HARDENED STEEL	HARDENED STEEL	HARDENED STEEL
<b>PLATING</b>	UNPLATED	RYCOTE CrVI free (SILVER)	RYCOTE CrVI free (SILVER)	RYCOTE CrVI free (SILVER)	RYCOTE CrVI free (SILVER)	CHROME PLATED (COUPLING) RYCOTE CrVI free (NIPPLE)	UNPLATED (COUPLING) RYCOTE CrVI free (NIPPLE)

## 200, 200S & 290 SERIES

### 200 SERIES – BRASS – 45 CFM

- CORROSION RESISTANT
- LONG LASTING
- HARD WEARING

Rated at 1300 litres per min. (45 CFM).  
Connect to **RYCO 200** Series nipples.

### 200S SERIES – STEEL – 45 CFM

- HARD WEARING
- LONG LASTING
- HARDENED SLEEVE

Rated at 1300 litres per min. (45 CFM).  
Connect to **RYCO 200S** Series nipples.

### 290 SERIES – STEEL – 90 CFM SUPER-HI-FLOW

- HARD WEARING
- LONG LASTING
- SELF LOCKING
- ONE TOUCH OPERATION (see page 337)
- HARDENED SLEEVE

Rated at an amazing 2500 litres per min. (90 CFM)  
These couplings connect directly onto existing  
**RYCO 200** and **200S** Series nipples.

#### 200 & 200S AUTOMATIC COUPLINGS

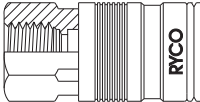
BSPP FEMALE	200 & 200S AUTOMATIC COUPLINGS		
	THREAD/ BARB	BRASS PART NO	STEEL PART NO
	1/4	200	200S
	3/8	243	243S

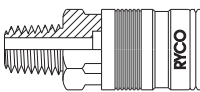
BSPT MALE	200 & 200S AUTOMATIC COUPLINGS		
		1/4	201
3/8		244	244S

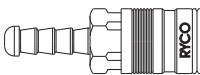
HOSE BARB	200 & 200S AUTOMATIC COUPLINGS			
		1/4	245	245S
		5/16	240	240S
3/8		241	241S	

#### BSPT MALE COUPLING NIPPLE SUITS 200, 200S & 290 SERIES

BSPT MALE	BSPT MALE COUPLING NIPPLE SUITS 200, 200S & 290 SERIES		
	THREAD BSPT	BRASS PART NO	STEEL PART NO
	1/8	204	
	1/4	202	202S
	3/8		251S
	1/2		252S

#### HOSE BARB COUPLING NIPPLE SUITS 200, 200S & 290 SERIES

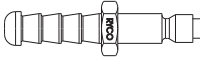
HOSE BARB	HOSE BARB COUPLING NIPPLE SUITS 200, 200S & 290 SERIES		
	THREAD BSPT	BRASS PART NO	STEEL PART NO
	3/16	256	
	1/4	205	205S
	5/16	206	206S
	3/8	206A	206AS
	1/2		254S

#### 290 AUTOMATIC COUPLINGS

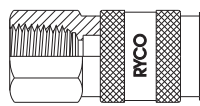
BSPP FEMALE	290 AUTOMATIC COUPLINGS	
	THREAD/ BARB	PART NO
	1/4	290
	3/8	292
	1/2	294

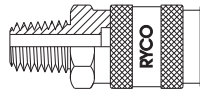
BSPT MALE	290 AUTOMATIC COUPLINGS		
		1/4	291
		3/8	293
1/2		295	

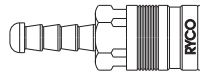
HOSE BARB	290 AUTOMATIC COUPLINGS		
		1/4	296
		5/16	297A
		3/8	298
1/2		299	

#### BSPP FEMALE COUPLING NIPPLE SUITS 200, 200S & 290 SERIES

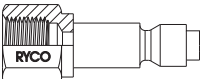
BSPP FEMALE	BSPP FEMALE COUPLING NIPPLE SUITS 200, 200S & 290 SERIES		
	THREAD BSPT	BRASS PART NO	STEEL PART NO
	1/8	255	
	1/4	203	203S
	3/8		266S
	1/2		270S

#### SCHRADER

SHORT	217	
LONG	217A	

### 300 SERIES - INDUSTRIAL

165 CFM

- HEAVY DUTY
- INDUSTRIAL STRENGTH
- BRASS VALVE
- STEEL COUPLING
- HARDENED SLEEVE

Rated at a big 4700 litres per min. (165 CFM).  
Suits RYCO 300 Series Automatic Coupling nipple.

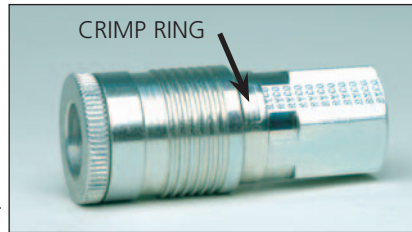

300 Series feature Crimp Ring construction. The Crimp Ring locks into grooves in the coupling, and ensures that the Coupling cannot be disassembled by high frequency vibrations or shock loads. "Factory Sealed" for the life of the Coupling.

#### 300 AUTOMATIC COUPLINGS

##### BSPP FEMALE

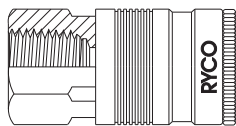

THREAD/ BARB	PART NO
3/8	322
1/2	320

##### BSPT MALE

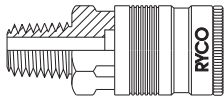

3/8	323
1/2	321

##### HOSE BARB

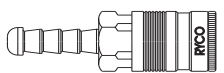

3/8	340
1/2	341

#### 300 COUPLING NIPPLES

##### BSPT FEMALE

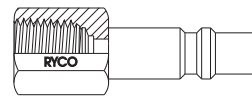

THREAD/ BARB	PART NO
3/8	330
1/2	303

##### BSPT MALE

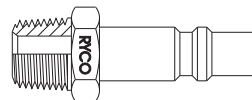

1/4	332
3/8	304
1/2	302

##### HOSE BARB

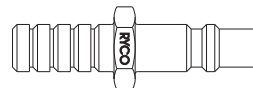

3/8	305
1/2	306
3/4	331

### 400 SERIES - SUPER-HI-FLOW

90 CFM

- HARD WEARING
- LONG LASTING
- STEEL COUPLING
- HARDENED SLEEVE

Rated at 2500 litres per min. (90 CFM).

This Series cross references with Nitto couplings and connects to RYCO 400 Series nipples.

#### 400 AUTOMATIC COUPLINGS

##### BSPP FEMALE

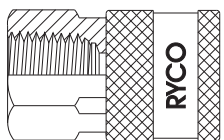

THREAD/ BARB	PART NO
1/4	420SF
3/8	430SF
1/2	440SF

##### BSPT MALE

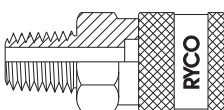

1/4	420SM
3/8	430SM
1/2	440SM

##### HOSE BARB

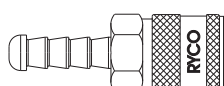

1/4	420SH
5/16	425SH
3/8	430SH
1/2	440SH

#### 400 COUPLING NIPPLES

##### BSPP FEMALE

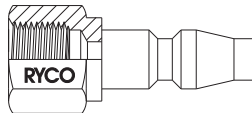

THREAD/ BARB	PART NO
1/8	410PF
1/4	420PF
3/8	430PF
1/2	440PF
SCHRADER LONG	417A

##### BSPT MALE

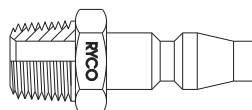

1/8	410PM
1/4	420PM
3/8	430PM
1/2	440PM

##### HOSE BARB

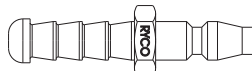

1/4	420PH
5/16	425PH
3/8	430PH
1/2	440PH

## 500R SERIES – RESPIRATORY BREATHING AIR 100 CFM

RYCO 500R Series Couplings are designed for Respiratory Breathing Air applications, where breathing air is supplied to the operator via air-line. They comply with the relevant clauses of **AS/NZS 1716** "Respiratory Protection Devices".

Disconnection of the Coupling requires two deliberate movements:

1. The Nipple must be pushed further into the Female Body.
2. While holding the Nipple in, retract the Sleeve.

This feature reduces the risk of accidental disconnection.

Additionally, **RYCO 500R** Series Coupling Nipples have a longer shank than **RYCO 500** Series.

**RYCO 500** Series Coupling Nipples cannot be connected to **RYCO 500R** Series Couplings.

### Recommended For:

Typical Respiratory Breathing Air applications; work in confined spaces, oxygen deficient or toxic areas, chemical processing and spraying, spray painting, rescue equipment, asbestos removal, sand blasting, tank cleaning, and fumigation.

**RYCO 500R** Series Couplings are **NOT RECOMMENDED** for Underwater Diving applications.

An Independent Test Report, showing compliance of **RYCO 500R** Series Couplings to **AS/NZS 1716-1994** "Respiratory Protection Devices" is available. This Test Report covers the following clauses of **AS/NZS 1716**:

### Clause 8.3.4 "Connectors and couplings"

"All air-line connections shall be of "safety type" i.e. requiring at least two deliberate actions to separate the connection or coupling" and

### Clause 8.4.6.1 "Strength of (air-line and) couplings".

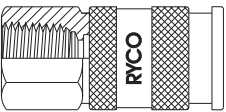
BSPT FEMALE	500R AUTOMATIC COUPLINGS	
	THREAD/ BARB	PART NO
	1/4	500R
	3/8	
	1/2	

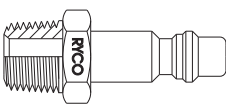
BSPT MALE	500R COUPLING NIPPLES	
	THREAD/ BARB	PART NO
	1/4	502R
	3/8	
	1/2	

### How to connect RYCO 500R Series Couplings:

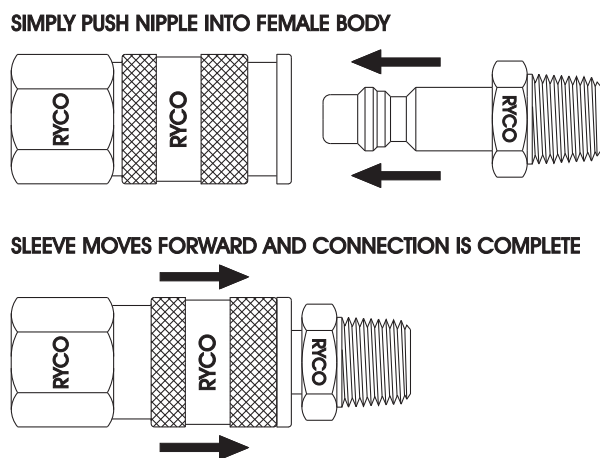

### How to disconnect RYCO 500R Series Couplings:

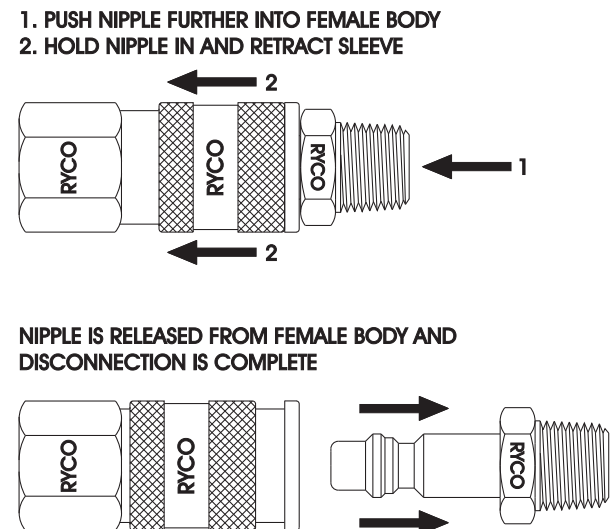

## 500 SERIES – SUPER-HI-FLOW

## 100 CFM

- HARD WEARING
- LONG LASTING
- SELF LOCKING
- ONE TOUCH OPERATION (see page 337)
- HARDENED SLEEVE

Rated at an amazing 2800 litres per min. (100 CFM). This Series cross references with CEJN couplings and connects to RYCO 500 Series nipple.

### 500 AUTOMATIC COUPLINGS

#### BSPT FEMALE

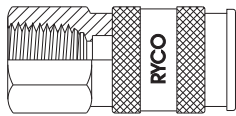

THREAD/ BARB	PART NO
1/4	500
3/8	543
1/2	546

#### BSPT MALE

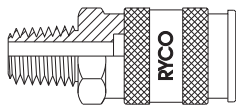

1/4	501
3/8	544
1/2	547

#### HOSE BARB

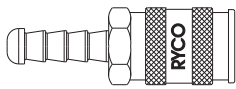

1/4	545
5/16	540
3/8	541
1/2	542

#### BSPP FEMALE

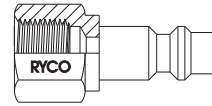

### 500 COUPLING NIPPLES

THREAD/ BARB	PART NO
1/4	503
3/8	566
1/2	570
SCHRADER LONG	517A

#### BSPT MALE

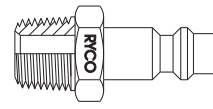

1/8	504
1/4	502
3/8	551
1/2	552

#### HOSE BARB

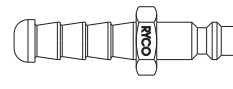

1/4	505
5/16	506
3/8	506A
1/2	554

## BLOW GUNS

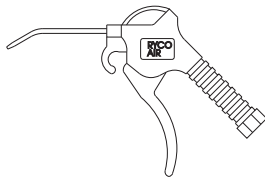

### EASY HAND CLASP BLOW GUN

THREAD	PART NO
1/4 BSPP	224

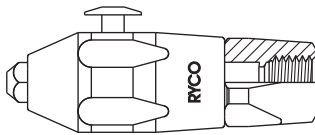

### PUSH BUTTON BLOW GUN

THREAD	PART NO
1/4 BSPP	223

### AIR-FLEX BLOW GUNS

- LEAKPROOF INTERNAL VALVE
- OPERATES BY SLIGHT PRESSURE BETWEEN HAND & THUMB
- RELAXING PRESSURE INSTANTLY SHUTS AIR OFF
- INCLUDES PART NO 2215 EXTENSION

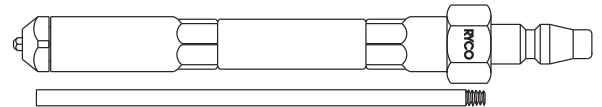

COUPLING STYLE	PART NO	COUPLING STYLE	PART NO
200 SERIES	222	400 SERIES	422
290 SERIES	222	500 SERIES	522

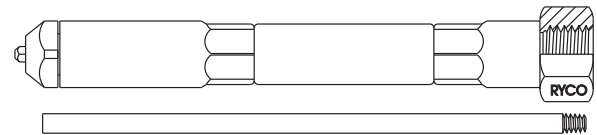

PART NO	COUPLING STYLE
1/4 BSPP	221

## AIR CHUCKS

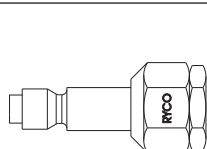

COUPLING STYLE	PART NO
200 & 290	216
400	416
500	516

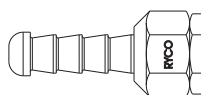

BARB SIZE	PART NO
1/4	211
3/8	213

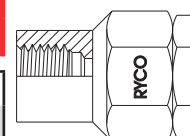

THREAD SIZE	PART NO
1/4 BSPT	214

## HOSE BARBS

### BARB - BSPT MALE

BARB	THREAD	PART NO	MAT
3/16	1/8	218A	B
3/16	1/4	218	B
1/4	1/8	219	B
1/4	1/4	207	B
1/4	3/8	268S	S
5/16	1/8	220	B
5/16	1/4	208	B
5/16	3/8	267S	S
3/8	1/8	260	B
3/8	1/4	209	B
3/8	3/8	307	S
3/8	1/2	309	S
1/2	1/4	210	B
1/2	3/8	308	S
1/2	1/2	310	S
1/2	3/4	310-8	S
3/4	1/2	310-10A	S
3/4	3/4	310-2A	S
3/4	1	310-9	S
1	3/4	310-7A	S
1	1	310-3A	S

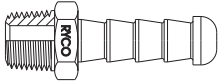

### BARB - BARB

BARB	PART NO	MAT
3/16	257	B
1/4	227	B
5/16	228	B
3/8	229	B
1/2	258	B

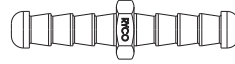

### BARB - 90° ELBOW

BARB	PART NO	MAT
1/4	372	S
5/16	375	S
3/8	377	S
1/2	379	S

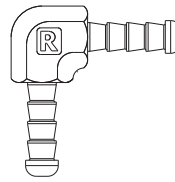

### BARB - BSPT MALE - 90° ELBOW

BARB	THREAD	PART NO	MAT
1/4	1/4	342	S
5/16	1/4	343	S
5/16	3/8	346	S
3/8	1/4	344	S
3/8	3/8	347	S
1/2	1/2	349	S

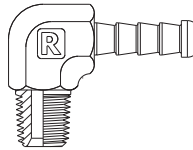

### BARB - BSPP FEMALE

BARB	THREAD	PART NO	MAT
3/16	1/4	259	B
1/4	1/4	236	B
1/4	3/8	269S	S
5/16	1/4	237	B
5/16	3/8	261S	S
3/8	1/4	238	B
3/8	3/8	262S	S
3/8	1/2	264S	S
1/2	3/8	263S	S
1/2	1/2	265S	S

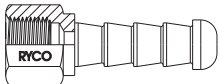

### BARB - TEE PIECE

BARB	PART NO	MAT
1/4	382	S
5/16	385	S
3/8	387	S
1/2	389	S

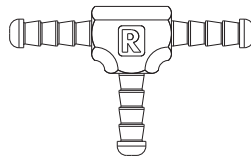

### BSPP - NUT & TAIL

BARB	THREAD	PART NO
1/4	1/4	231
5/16	1/4	232

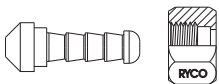

Steel Nut/Brass Tail

### BARB - BSPT MALE - TEE PIECE

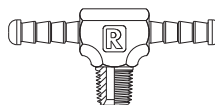

BARB	THREAD	PART NO	MAT
1/4	1/4	352	S
5/16	1/4	353	S
5/16	3/8	356A	S
3/8	1/4	354	S
3/8	3/8	357	S
1/2	1/2	359	S



PLEASE NOTE: MAT (material) column B = BRASS S = PLATED STEEL

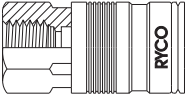
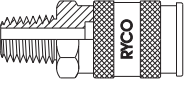

### AIRLINE COUPLINGS 1 PER CARD

	THREAD/ BARB	200 SERIES	290 SERIES	400 SERIES
<b>BSP FEMALE</b> 	1/4	P200	P290	P420SF
	3/8		P292	P430SF
<b>BSPT MALE</b> 	1/4	P201	P291	P420SM
	3/8		P293	P430SM
<b>HOSE BARB</b> 	1/4		P296	P420SH
	5/16		P297A	P425SH
	3/8		P298	P430SH

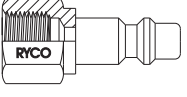
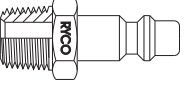
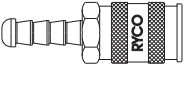

### COUPLING NIPPLES 2 PER CARD

	THREAD/ BARB	200 SERIES	290 SERIES	400 SERIES
<b>BSPP FEMALE</b> 	1/4	P203	P203S	P420PF
	3/8		P266S	P430PF
<b>BSPT MALE</b> 	1/4	P202	P202S	P420PM
	3/8		P251S	P430PM
<b>HOSE BARB</b> 	1/4	P205	P205S	P420PH
	5/16	P206	P206S	P425PH
	3/8	P206A	P206AS	P430PH

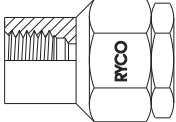
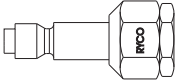
### AIR CHUCK 1 PER CARD

	THREAD BSPT	PART NO
	1/4 FEM	P214
COUPLING STYLE	PART NO	
	200 & 290	P216

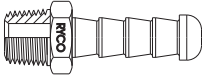
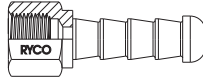
### AIRLINE FITTINGS 2 PER CARD

	BARB	THREAD	PART NO
	1/4	1/4	P207
	1/4	3/8	P268S
	5/16	1/4	P208
	5/16	3/8	P267S
	3/8	1/4	P209
	3/8	3/8	P307
	1/4	1/4	P236
	1/4	3/8	P269S
	5/16	1/4	P237
	5/16	3/8	P261S
	3/8	1/4	P238
	3/8	3/8	P262S
	1/4		P227
	5/16		P228
	3/8		P229

### BLOW GUNS 1 PER CARD

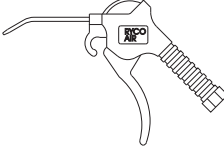
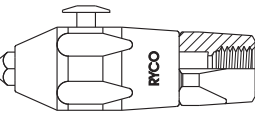
	THREAD BSPP	PART NO
	1/4 FEM	P224
P224 includes 202S Airline Nipple		
	1/4 FEM	P223

Intro

Hose

Couplings

Adaptors

Accessories

Filters

Technical





### P2000 RYCO HANG SELL MERCHANDISER

15 peg merchandiser rack, complete with 50 packs of popular **RYCO 200** Series couplings and nipples; and 25 packs of hose barb fittings, blow guns and air chucks. Dimensions of merchandiser rack 420 mm high x 450 mm wide plus header card 250 mm high. Rack is suitable for wall mounting, and free standing with in-built rear prop.

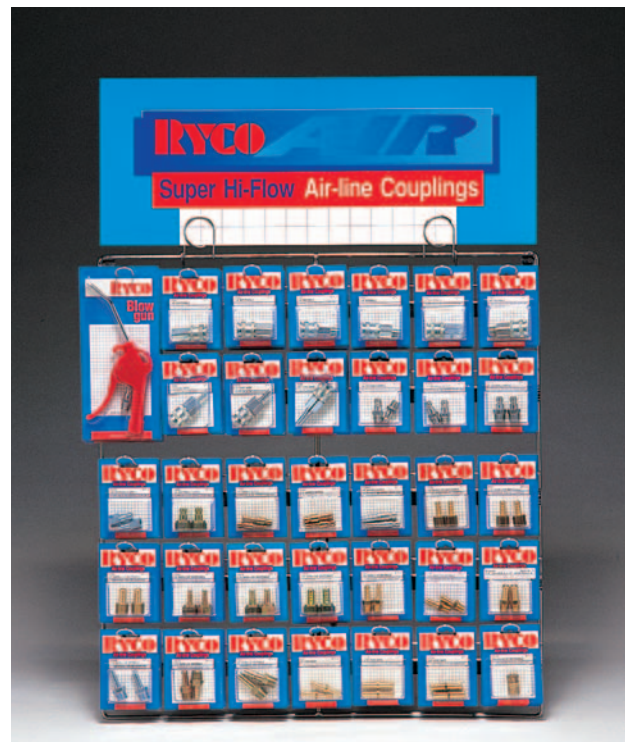

### P2900 RYCO HANG SELL MERCHANDISER

35 peg merchandiser rack, complete with 51 packs of popular **RYCO 290** Series couplings and **200S** Series nipples; and 51 packs of hose barb fittings, blow guns and air chucks. Dimensions of merchandiser rack 700 mm high x 660 mm wide plus header card 250 mm high. Rack is suitable for wall mounting.

### P4000 RYCO HANG SELL MERCHANDISER (Not shown)

35 peg merchandiser rack, complete with 48 packs of popular **RYCO 400** Series couplings and nipples; and 51 packs of hose barb fittings, blow guns and air chucks. Dimensions of merchandiser rack 700 mm high x 660 mm wide plus header card 250 mm high. Rack is suitable for wall mounting.